



# COOK



## ACRU-B

### Upblast Centrifugal Exhaust Ventilator Roof Mounted/Belt Drive

#### STANDARD CONSTRUCTION FEATURES:

All aluminum housing - Backward inclined all aluminum wheel - Two piece top cap with stainless steel quick release latches - One piece bottom spinning - Welded curb cap corners - Birdscreen - Vibration isolators - Lifting Lugs - Permanently lubricated ball bearing motors - Oil and heat resistant, static conducting belts - Adjustable pitch drives through 5 hp motor - Corrosion resistant fasteners - Regreasable bearings in a cast iron pillow block housing, rated at 200,000 hours average life - All fans factory adjusted to specified fan RPM - Transit tested packaging. Standard motors ship factory installed.

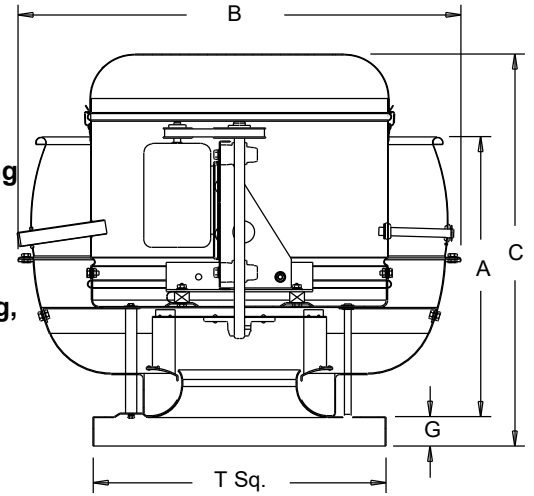

#### Performance

Qty	Catalog Number	Fan RPM	Power (HP)	FEG
1	120R2B	1313	.147	n/a(<1HP)

#### Motor Information

HP	RPM	Volts/Ph/Hz	Enclosure	FLA	Mounted
1/6	1140	115/1/60	ODP -SE	4.4	Yes

FLA based on NEC (2017) Table 430.248

#### Accessories:

DRIVES (1.5 SF) @ 1313 RPM

#### Dimensions (inches)

A	19-1/16
B	30-3/16
C	28-1/4
G	2
T Sq.	20
Roof Open. Sq.*	15-1/2

NOTE: Accessories may affect dimensions shown.

Weight(lbs)***	Shipping	76	Unit	59
----------------	----------	----	------	----

\* Roof opening size for curbs supplied by Cook only.

\*\*\*Includes fan, motor & accessories.

